

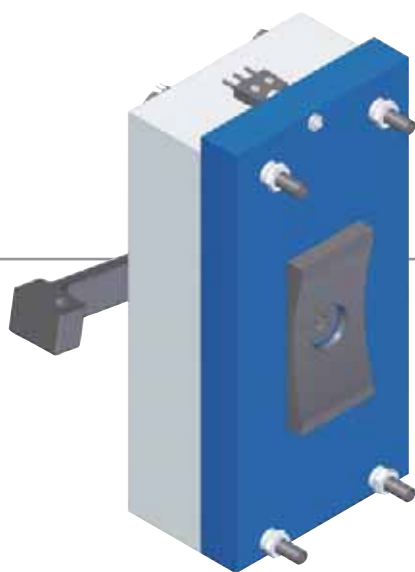

ERS VAR12-01

Electrically Released brake for Elevators



High modular braking system for modern elevator concept

The ERS VAR12-01 is a single surface brake. With 2 brakes, the braking system complies with EN81-1 and protects the elevator against ascending overspeed and unintended movement.

Elevator Applications

- ◆ Gearless motors

Warner Electric is a world leader in the design and manufacturing of Electrically Released Brakes for the elevator market.

We offer a full range of brakes and specialize in customized solutions to meet your specific performance and installation requirements.

We have over 60 years of experience delivering high technology, cost effective braking systems. We offer production, engineering and application support from our facilities in Europe, Asia and U.S.A. Our engineers, factories and extensive sales network are at your service.

- ◆ EC 95/16 certified
- ◆ Torque capacity according to drum diameter
- ◆ Overexcitation or monotension voltage
- ◆ Hand release on request
- ◆ Redundant capability according EN 81-1 when two or more brakes are used
- ◆ Large braking torques can be achieved by using several brakes
- ◆ Microswitch equipped upon request
- ◆ Nearly maintenance free (further information in our service manual)



Industrie Service





ERS VAR12-01

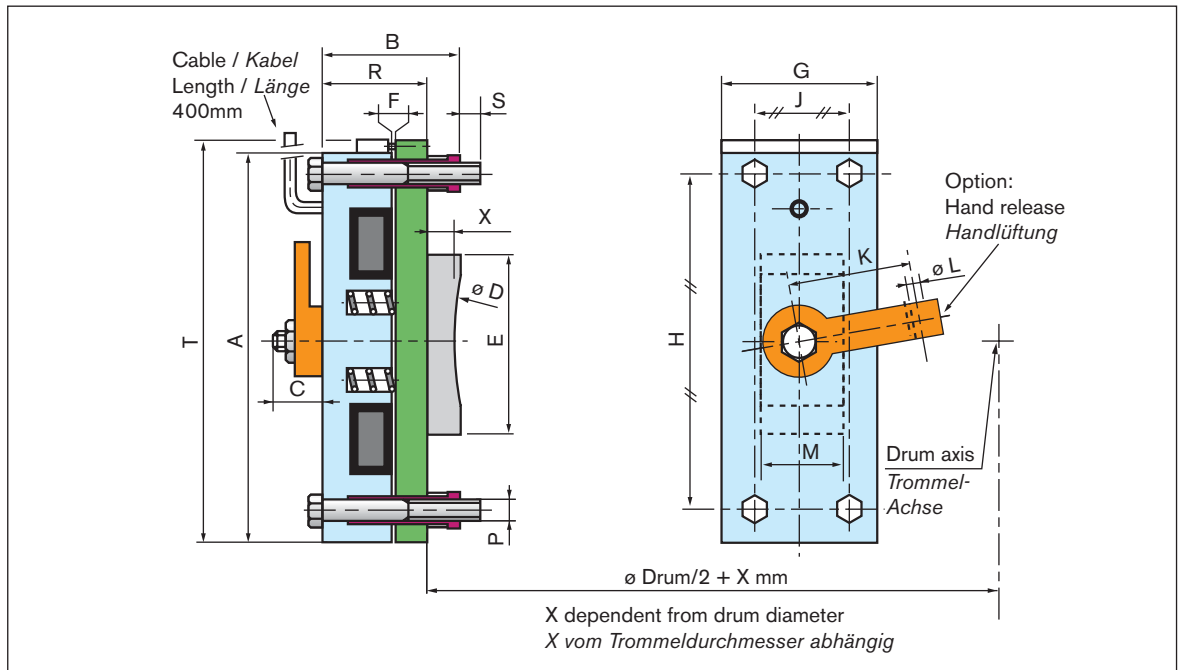

Tolerances on the supply voltage at the brake terminals +5% / -10% (NF C 79-300).
 Die Spannungstoleranz an der Anschlussklemme der Bremse beträgt +5% / -10% (NF C 79-300).

VAR		12-01
A	mm	240
B	mm	83
C	mm	25
E	mm	100
F nominal	mm	0,3
G	mm	120
H	mm	220
J	mm	75
K	mm	112,5
L	mm	9
M	mm	50
P	mm	4 x M8
Weight/Gewicht	kg	16,5
R	mm	75
S	mm	16
T	mm	250
Voltage/Spannung*	VDC	24
ED	%	40
Connection/Anschluß		Cable/Kabel
D has to be given by the customer Maß D bei Bestellung angeben		

*w/o Overexcitation / ohne Übererregung

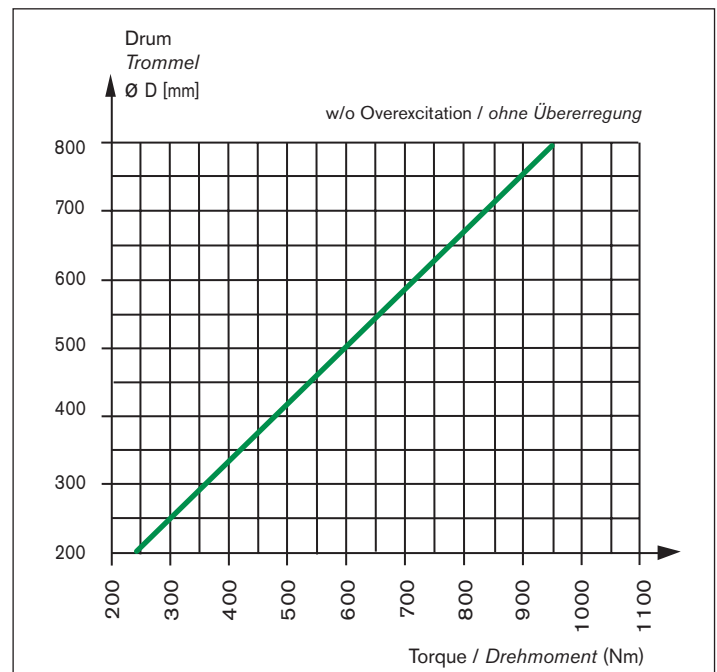

Linear speed (outer diameter of disc): standard up to 5 m/s
 Lineare Geschwindigkeit (Außendurchmesser der Scheibe): bis 5 m/s